

## UPGRADE YOUR SYSTEM



### ROLTEC® ELECTRIC TARP CONVERSION

- Motor controls the tension of the tarp, when heaped loads settle, touch the switch to tighten tarp
- Worm gears create an instant, positive lock
- Rotating and telescoping motor mount allows roll tube to rise and flex over heaped loads, reducing stress on the drive components and pivot arm
- 4 springs create positive return tension when closing the tarp system, no elbows or joints to break

### COMMAND-10® REMOTE

- Remote and receiver come pre-programmed and easy to re-program
- Remote controls 10 devices from more than 100 ft. away or from the comfort of your cab
- Remote shuts off when the lid is closed or after 3 minutes of inactivity
- Built-in overload protection
- Stainless steel terminals and hardware

Command Station available

## ORDER NOW

Measure your equipment to start your order process:

Equipment Type: \_\_\_\_\_

A. Upper Box Length: \_\_\_\_\_

B. Upper Box Width: \_\_\_\_\_

C. Box Height (from ground): \_\_\_\_\_

Fabric Color: \_\_\_\_\_

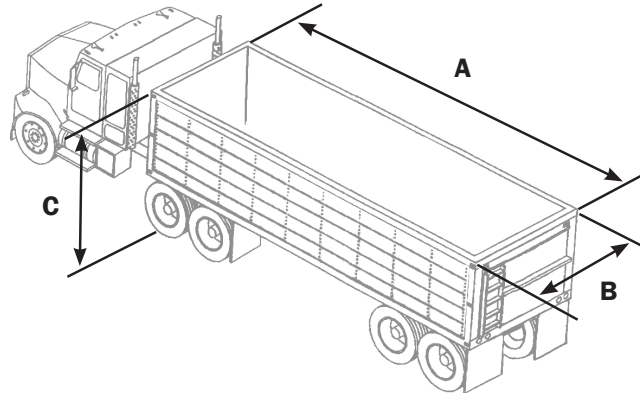

**AGRICOVER.COM**

© 2016 AGRI-COVER, INC. ALL RIGHTS RESERVED.

Distributed By:



Billings, MT  
Hastings, NE  
Valley City, ND  
Yakima, WA  
Phone: 800-437-9702  
Fax: 800-313-3299  
www.feiinc.com

**For semi and pup trailers, grain carts, farm trucks, tenders and spreaders**

**American Made**

Tested. Trusted. Guaranteed.

## EZ-LOC® ROLL-UP TARP

A LIGHTER, BETTER SEALING ROLL TARP!



### 2" ALUMINUM ROLL TUBE

- Rust resistant and strong, yet lightweight to minimize tarp wear
- Rope channel is a continuous tarp attachment creating uniform tension for a better fitting and longer lasting tarp

### CUSTOM END CAPS | ELECTRIC READY\*

- Low profile wind deflector is hand and tarp friendly
- Crimped standing seam is self sealing, flexible with no welds to break
- Integrated weather sealing rib

### HEAVY DUTY ZINC PLATED U-JOINT

- 21 splines for fine tuning tarp tension

### TARP CONSTRUCTION | ELECTRIC READY

- Welded 12" reinforced ends
- Webbing reinforcements for added strength
- Premium commercial grade, UV resistant 18 and 22 oz. vinyl fabric remains flexible at -40°

### QUICK RELEASE ALUMINUM TARP STOPS\*

- Integrated set screw on front and rear to eliminate tube sliding
- Open pin channel prevents seizing up
- No brittle die cast metal to break off and tear the tarp
- Opens and closes freely for easy removal

### ADJUSTABLE CRANK HANDLE WITH PINLESS RETAINER\*

- Easy in, easy out system saves time

### FRONT BUNJI RETURN SYSTEM

- Assists the operator with pulling action for easier operation when closing the tarp
- Tarp friendly, bunji attachment bracket

### OPTIONS

- Upgrade bunji return with an in roll tube spring return or front/rear cable return system

### FASTENERS\*

\*Available in stainless steel