

UPGRADE YOUR SYSTEM



SRT® ELECTRIC CONVERSION

- Slim, single-motor arm design fits between the cab and the box of a farm truck (7" minimum clearance required)
- Converts systems up to 24'
- Maximizes the existing tarp's dual spool and in-the-tube torsion springs
- Rocker Switch standard

COMMAND-10® REMOTE

- Remote and receiver come pre-programmed and easy to re-program
- Remote controls 10 devices from more than 100 ft. away or from the comfort of your cab
- Remote shuts off when the lid is closed or after 3 minutes of inactivity
- Built-in overload protection
- Stainless steel terminals and hardware
- Weather and impact resistant receiver
- Uses common AAA batteries

Command Station available

Measure your equipment to start your order process:

Equipment Type: _____

A. Upper Box Length: _____

B. Upper Box Width: _____

C. Box Height (from ground): _____

Fabric Color: _____

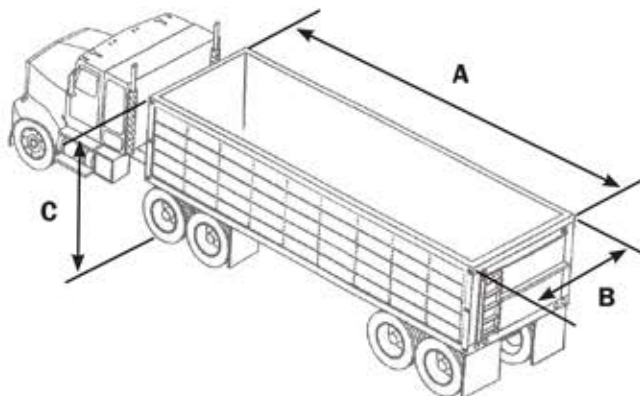

AGRICOVER.COM

© 2016 AGRI-COVER, INC. ALL RIGHTS RESERVED.

Distributed By:



Billings, MT
Hastings, NE
Valley City, ND
Yakima, WA
Phone: 800-437-9702
Fax: 800-313-3299
www.feinc.com



Our premium system for farm trucks, fertilizer boxes, grain carts, and wagons up to 24'

**American Made
Tested. Trusted. Guaranteed.**



SPRING LOADED SPOOLS

- Provide continuous tarp tension while rolling and unrolling, even in windy conditions

TENSION RATCHETS*

- Allow for fine tuning tarp tension during initial install
- No need to adjust

EXTRA DURABLE 3" ALUMINUM ROLL TUBE

- Strong, yet lightweight offers a faster and straighter roll
- Rope channel is a continuous tarp attachment creating uniform tension for a better fitting and longer lasting tarp

TELESCOPING CRANK HANDLE WITH FLEX DRIVE SYSTEM

- Rolls and unrolls the tarp at many angles with ease
- Mounts at the front, rear or sides

CUSTOM END CAPS | ELECTRIC READY*

- Low profile wind deflector is hand and tarp friendly
- Crimped standing seam is self sealing, flexible with no welds to break
- Integrated weather sealing rib
- Available in 7 and 12" rises

QUICK RELEASE ALUMINUM TARP STOPS*

- Integrated set screw on front and rear to eliminate tube sliding
- Open pin channel prevents seizing up
- No brittle die cast metal to break off and tear the tarp
- Opens and closes freely for easy removal

TARP CONSTRUCTION | ELECTRIC READY

- Premium commercial grade, UV resistant 18 oz. vinyl fabric remains flexible at -40°

NYLON CRANK HANDLE RETAINER*

- Low profile design easily mounts close to the box

FASTENERS*